

# Roadblocker - High Impact or Terrain

For security where arm barriers or bollards is not an effective enough deterrent.

## Design

A Citadel road blocker provides higher levels of security, to stop unauthorised traffic, create effective traffic control and supply higher levels of security for and including military type applications.

Citadel road blockers are designed to withstand light impact and still operate, keeping security levels.

Available with or without traffic lights for additional control.

Designed to withstand vehicle impacts *depending upon design* from 7.5 tonnes, 10 tonnes to maximum 20 Tonnes.

Operating speeds 2 seconds to 5 seconds, *depending upon height*

## Height; When activated.

High Impact

600mm, 800mm, 1000mm

Terrain

340mm, 500mm, 650mm

## Widths

From 2.00m to 8.00m in 500mm increments.

\*Other sizes available on request and depending upon type.

## Operation

### Hydraulic system

Immersed pump with extra heavy duty valves (24V DC).

Pneumatic version available on High impact version.

400V Three phase 10-amp or Single phase 16 amp power supply required. 100% rated.

PLC logic controls in separate control cabinet.

High security anti-tamper control cabinet.

### Surface Treatment

- Galvanised and primed yellow/black as standard:

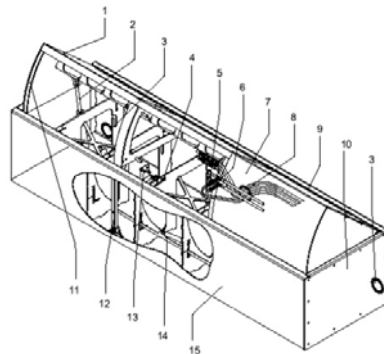

- |    |                             |     |                               |
|----|-----------------------------|-----|-------------------------------|
| 1. | Road Plate                  | 9.  | Hinge                         |
| 2. | Hydraulic or *Pneumatic ram | 10. | Side plate                    |
| 3. | Drainage points             | 11. | Reinforced steel rising wedge |
| 4. | Bracing                     | 12. | Height adjustment             |
| 5. | Optional control            | 13. | Ground level lock             |
| 6. | Access control connection   | 14. | Option—locking ram            |
| 7. | Curved front cover plate    | 15. | Steel cabinet                 |
| 8. | Hydraulic connections       |     |                               |

\* *Optional pneumatic operation*



**Citadel**

Unit F1, Halesfield 4,  
Telford, Shropshire TF7 4AP, England  
Tel: +44 (0) 1952 410 020  
Fax: +44 (0) 1952 411 144  
E.mail: mail@citadelsecurityuk.com  
www.citadelsecurityuk.com